

Nokia Wireless Headset (HS-36W) User Guide

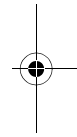

9239356

Issue 2 EN

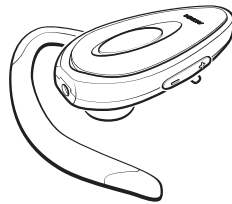
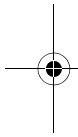
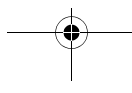



DECLARATION OF CONFORMITY

We, NOKIA CORPORATION declare under our sole responsibility that the product HS-36W is in conformity with the provisions of the following Council Directive: 1999/5/EC. A copy of the Declaration of Conformity can be found at http://www.nokia.com/phones/declaration_of_conformity/.

CE 0681

Copyright © 2005 Nokia. All rights reserved.

Reproduction, transfer, distribution or storage of part or all of the contents in this document in any form without the prior written permission of Nokia is prohibited.

Nokia and Nokia Connecting People are registered trademarks of Nokia Corporation. Other product and company names mentioned herein may be trademarks or tradenames of their respective owners.

Bluetooth is a registered trademark of Bluetooth SIG, Inc.

Nokia operates a policy of continuous development. Nokia reserves the right to make changes and improvements to any of the products described in this document without prior notice.

Under no circumstances shall Nokia be responsible for any loss of data or income or any special, incidental, consequential or indirect damages howsoever caused.

The contents of this document are provided "as is". Except as required by applicable law, no warranties of any kind, either express or implied, including, but not limited to, the implied warranties of merchantability and fitness for a particular purpose, are made in relation to the accuracy, reliability or contents of this document. Nokia reserves the right to revise this document or withdraw it at any time without prior notice.

The availability of particular products may vary by region. Please check with the Nokia dealer nearest to you.

Unauthorized changes or modifications to this device may void the user's authority to operate the equipment.

Export Controls

This device may contain commodities, technology or software subject to export laws and regulations from the US and other countries. Diversion contrary to law is prohibited.

9239356/Issue 2 EN

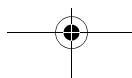
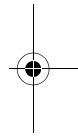
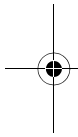



Contents

1. Introduction	4	3. Basic use	8
Bluetooth wireless technology	4	Wear the headset on either ear	8
2. Get started.....	5	Call handling.....	8
Chargers and batteries.....	5	Store the headset properly	9
Charge the battery	6	Troubleshooting	9
Switch the headset on or off	6	4. Battery information	10
Pair the headset with a compatible phone	6	Care and maintenance	11

English

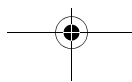
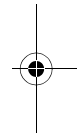
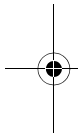

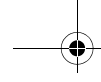

Introduction



1. Introduction

The Nokia Wireless Headset (HS-36W) can be used with compatible phones that support Bluetooth wireless technology. This allows you freedom to make and receive calls while on the move or in the office.

Read this user guide carefully before using the headset. Read also the user guide for your phone, which provides important safety and maintenance information. Keep the headset out of reach of small children.

■ Bluetooth wireless technology

Bluetooth wireless technology allows you to connect compatible communication devices without cables. A Bluetooth connection does not require that the phone and the headset be in line of sight, but both devices should be within 10 meters (30 feet) of each other. Connections may be subject to interference from obstructions, such as walls, or other electronic devices.

The headset is compliant with the Bluetooth Specification 1.2 supporting the following profiles: Headset profile 1.1 and Hands-free Profile 1.0. Check with the manufacturers of other devices to determine their compatibility with this device.

There may be restrictions on using Bluetooth technology in some locations. Check with your local authorities or service provider.

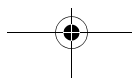
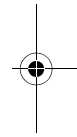
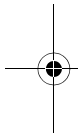

2. Get started

The headset contains the following parts:

- Indicator light (1)
- Volume keys (2)
- Charging socket (3)
- Answer/end key (4)
- Earhook (5)
- Nokia Charger Adapter cable (CA-71) (6)

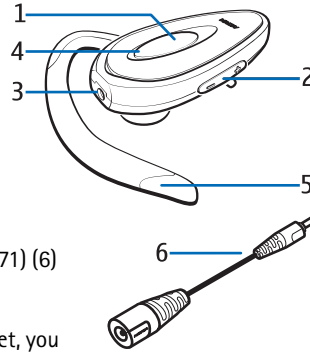

Before you can start to use the headset, you must charge the battery, and pair a compatible phone with the headset.



Note: Parts of the headset are magnetic. Metallic materials may be attracted to the headset, and persons with a hearing aid should not hold the headset to the ear with the hearing aid. Do not place credit cards or other magnetic storage media near the headset, because information stored on them may be erased.

■ Chargers and batteries

Check the model number of any charger before using it with this device. The Nokia Wireless Headset (HS-36W) is intended for use with the ACP-12 and LCH-12 chargers.



Warning: Use only batteries and chargers approved by Nokia for use with this particular enhancement. The use of any other types may invalidate any approval or warranty, and may be dangerous.

For availability of approved enhancements, please check with your dealer. When you disconnect the power cord of any enhancement, grasp and pull the plug, not the cord.

Get started

■ Charge the battery

The headset has an internal, nonremovable, rechargeable battery. Do not attempt to remove the battery from the device, as you may damage the device.

1. Ensure that the Nokia Charger Adapter cable (CA-71) is connected to the charger that is supplied with the headset. If this is not the case, connect the one end of the adapter cable to the charger cable.
2. Connect the adapter cable to the headset.
3. Connect the ACP-12 charger to a wall outlet or the LCH-12 charger to the accessory power outlet of your car. The blue indicator light is continuously displayed during charging.

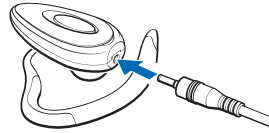

The headset is switched off and cannot be used during charging.

4. When the battery is fully charged, the blue indicator light switches off. Disconnect the charger from the wall outlet or the accessory power outlet and the headset. When you disconnect the power cord of the charger, grasp and pull the plug, not the cord.

The fully charged battery has power for up to 6 hours of talk-time or up to 110 hours of standby time. (In the standby mode, the headset is switched on but no call is in progress.)

When the battery is running out of power, the red indicator light lights up. Charge the battery.

■ Switch the headset on or off

To switch on, press the answer/end key for about 1 second. To switch off, press and hold the answer/end key for about 5 seconds.

■ Pair the headset with a compatible phone

Make sure that the headset is on, and put it in pairing mode by pressing the answer/end key and the volume up (+) key at the same time over 5 seconds until the blue indicator light lights up. The indicator light



Get started



remains on for 5 minutes, during which you can pair the headset with a compatible mobile phone.

1. Set the phone to search for Bluetooth devices. See the user guide of your phone for instructions.
2. When your phone finds the headset, confirm the pairing from your phone.
3. When prompted for the Bluetooth passcode of the headset, enter 0000.

If the pairing was unsuccessful, try to pair the devices again.

You only need to pair the headset with your phone once.

If the pairing was successful, the blue indicator light starts to flash. The headset is now in the standby mode and ready for use.

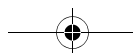
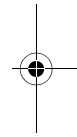
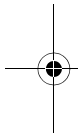

Basic use

3. Basic use

■ Wear the headset on either ear

The headset is ready to wear on the right ear. If you want to use it on the left ear, gently flip (1) and rotate the earhook (2).

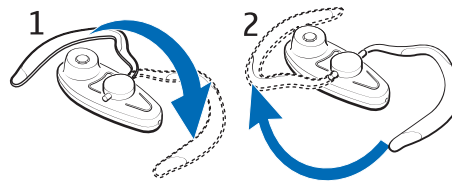

■ Call handling

To answer a call, press the answer key on your mobile phone, or press the answer/end key on the headset briefly. If you do not want to answer a call, press and hold the answer/end key on the headset for about 1 second.

To make a call, dial the number with your mobile phone, and press the answer key on your phone. The call is automatically transferred to the headset.

To redial the last called number, press and hold the answer/end key on your headset for about 1 second when no call is in progress.

If your phone supports voice dialing and there is no call in progress, press the answer/end key on the headset briefly, and proceed with voice dialing as described in the user guide of your phone. For the best result, record the voice tag through your headset.

To increase or decrease the volume of the headset, press either volume key until the satisfactory volume level is reached.

To end a call, press the end key on your mobile phone, or press the answer/end key on your headset briefly.



■ Store the headset properly

Always store the headset with the power off and safely protected. Avoid storage in high temperatures (above 60°C/134°F), such as in a hot vehicle or in direct sunlight. Storage in high temperatures can degrade performance and reduce the battery life. Low temperatures (down to -10°C/14°F) shorten the battery life and may affect operation.

■ Troubleshooting

The audio quality is poor.

For optimal performance, wear the headset and your mobile phone on the same side of your body or in line of sight.

I have pairing problems even though my phone indicates otherwise.

You may have deleted the headset pairing in your mobile phone. Pair the devices again.

There is no audio in the headset. Do the following:

- Increase the volume on the headset by pressing the volume up (+) key.
- Ensure that the headset is paired with the phone.
- Make sure that the phone is connected to the headset. If not, try to pair the devices again.

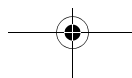
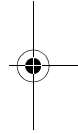
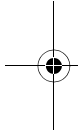



Battery information



4. Battery information

Your device is powered by a rechargeable battery. The full performance of a new battery is achieved only after two or three complete charge and discharge cycles. The battery can be charged and discharged hundreds of times, but it will eventually wear out. Recharge your battery only with Nokia approved chargers designated for this device.

Unplug the charger from the electrical plug and the device when not in use. Do not leave a fully charged battery connected to a charger, since overcharging may shorten its lifetime. If left unused, a fully charged battery will lose its charge over time.

Use the battery only for its intended purpose. Never use any charger or battery that is damaged.

Leaving the device in hot or cold places, such as in a closed car in summer or winter conditions, will reduce the capacity and lifetime of the battery. Always try to keep the battery between 15°C and 25°C (59°F and 77°F). A device with a hot or cold battery may not work temporarily, even when the battery is fully charged. Battery performance is particularly limited in temperatures well below freezing.

Do not dispose of batteries in a fire as they may explode. Batteries may also explode if damaged. Dispose of batteries according to local regulations. Please recycle when possible. Do not dispose as household waste.

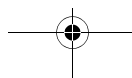
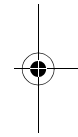
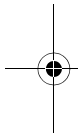

Care and maintenance

English

Your device is a product of superior design and craftsmanship and should be treated with care. The suggestions below will help you protect your warranty coverage.

- Keep all accessories and enhancements out of the reach of small children.
- Keep the device dry. Precipitation, humidity and all types of liquids or moisture can contain minerals that will corrode electronic circuits. If your device does get wet, remove the battery and allow the device to dry completely before replacing it.
- Do not use or store the device in dusty, dirty areas. Its moving parts and electronic components can be damaged.
- Do not store the device in hot areas. High temperatures can shorten the life of electronic devices, damage batteries, and warp or melt certain plastics.
- Do not store the device in cold areas. When the device returns to its normal temperature, moisture can form inside the device and damage electronic circuit boards.
- Do not attempt to open the device other than as instructed in this guide.
- Do not drop, knock, or shake the device. Rough handling can break internal circuit boards and fine mechanics.
- Do not use harsh chemicals, cleaning solvents, or strong detergents to clean the device.
- Do not paint the device. Paint can clog the moving parts and prevent proper operation.

All of the above suggestions apply equally to your device, battery, charger, or any enhancement. If any device is not working properly, take it to the nearest authorized service facility for service.

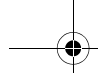

Battery information

